



krzesła, fotele i sofy biurowe

krzesła, fotele i sofy biurowe

fotele biurowe i gabinetowe

	astro new p	10
	astro new d	11
	axis	4
	axis.exe	3
	class	16
	class.exe	15
	crown	8
	crown.exe	7
	emotion	13
	emotion.exe	12
	kvadro	18
	max	20

krzesła konferencyjne

	ari	32
	astro new d2	10
	axis.exe v	5
	axis v	6
	class v	17
	crown.exe v	9
	crown v	9
	ecco	28
	emotion q	14
	emotion v	14
	emotion x	14
	evolution	22

	fly	24
--	-----	----

	fresh	27
---	-------	----

	gloss	31
---	-------	----

	kadr	25
---	------	----

	kvadro v	19
---	----------	----

	layer	32
--	-------	----

	malika	26
---	--------	----

	penta	30
---	-------	----

	trans	21
---	-------	----

	wing	25
---	------	----

sofy i fotele

	ancre	34
---	-------	----

	argo	44
---	------	----

	cube	41
--	------	----

	gaia	35
---	------	----

	icon	36
---	------	----

	oval	33
---	------	----

	sofia	38
---	-------	----

	vela	37
--	------	----

stoły składane i stoliki szklane

	flexa	48
---	-------	----

	tilt	46
---	------	----

	toro	47
---	------	----

	x-table	48
---	---------	----

Producent/Euronova zastrzega sobie prawo do wprowadzania zmian technicznych w oferowanych produktach nie wpływających na wytrzymałość i komfort użytkowania, bez dodatkowego informowania.

Producent zastrzega sobie prawo do wprowadzania zmian kolorystycznych, wzornictwa, wymiarów i funkcji prezentowanych wyrobów.

Producent zastrzega sobie prawo do zmiany wyglądu, cech i parametrów technicznych urządzenia w celu poprawy jakości produktu.



AXIS, AXIS.EXE

1. Ruch krzesła na kółkach.
2. Regulacja wysokości podnośnikiem pneumatycznym.
3. Obrót wokół własnej osi.
4. Mechanizm synchroniczny z multiblokiem, regulacja siły odchylenia oparcia z systemem łagodnego powrotu.
5. Wspomaganie lędźwiowej części kręgosłupa regulowane poprzez specjalny mechanizm.
6. Zagłówek o regulowanej wysokości do 5 cm.

Podłokietniki:

7. Regulacja na głębokości do 6 cm.
8. Regulacja kątowa w 3 pozycjach.

1. Movement on castors.
2. Gas height adjustment of the seat.
3. Rotation on axis.
4. Synchron mechanism seat/back with multiblock, tension adjustment and anti-shock system.
5. Lumbar Pad for customize the exact support for various spinal shapes.
6. Height adjustable headrest (5 cm.)

Armrests:

7. Horizontal sliding (6 cm.).
8. Horizontal rotation (3 pos.).



axis





axis v





crown



CROWN, CROWN.EXE

1. Ruch krzesła na kółkach.
2. Regulacja wysokości podnośnikiem pneumatycznym.
3. Obrót wokół własnej osi.
4. Mechanizm synchroniczny z multiblokiem, regulacja siły odchylenia oparcia z systemem łagodnego powrotu.
5. Wspomaganie lędźwiowej części kręgosłupa regulowane poprzez specjalny mechanizm.
6. Zagłówek o regulowanej wysokości i kącie nachylenia.

Podłokietniki:

7. Regulacja wysokości (10 cm - 8 pozycji).
8. Regulacja pozioma 30°.

1. Movement on castors.
2. Gas height adjustment of the seat.
3. Rotation on axis.
4. Synchron mechanism seat/back with multiblock, tension adjustment and anti-shock system.
5. Lumbar Pad for customize the exact support for various spinal shapes.
6. Height with angle and height adjustment.

Armrests:

7. Height adjustment (10 cm - 8 positions).
8. Horizontal rotation 30°.



crown.exe v



crown v

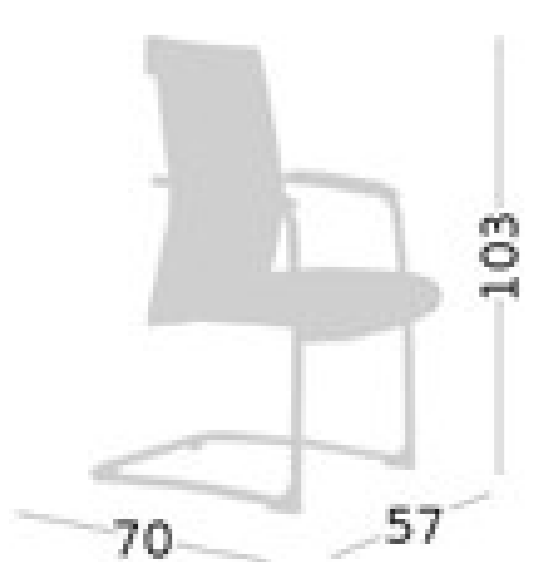

astro new p



astro new d2

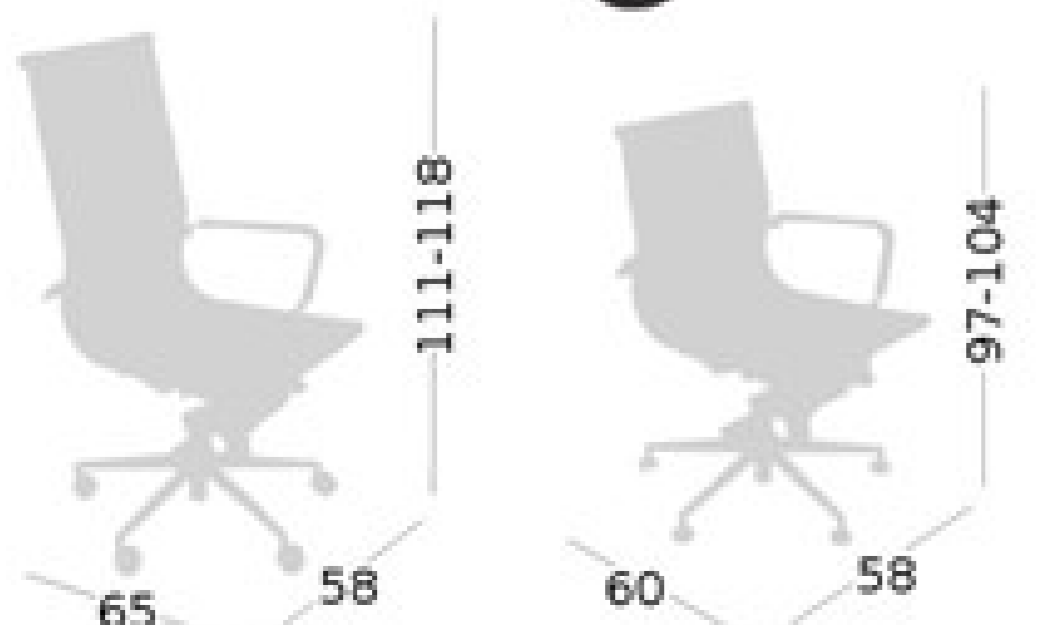

astro new d





EMOTION, EMOTION.EXE

1. Ruch krzesła na kółkach.
2. Regulacja wysokości podnośnikiem pneumatycznym.
3. Obrót wokół własnej osi.
4. Mechanizm synchroniczny regulujący kąt nachylenia oparcia.
5. Regulacja lędźwiowa.
6. Przesuw poziomy siedziska (3,5 cm).
7. Regulacja wysokości oparcia (6 cm).

Modele zaopatrzone w regulowane podłokietniki:

8. Regulacja wysokości (10 cm - 8 pozycji)
9. Rotacja pozioma 30° i regulowany rozstaw.

10. Zagłówek o regulowanej wysokości i kącie nachylenia (dotyczy EMOTION.EXE).

1. Movement on castors.
2. Gas height adjustment of the seat.
3. Rotation on axis.
4. Synchron mechanism seat/back lockable.
5. Adjustable lumbar support.
6. Sliding seat (3,5 cm).
7. Height adjustment of the back (6 cm).

Models with adjustable armrests:

8. Height adjustment (10 cm. - 8 pos.)
9. Horizontal sliding and 30° totation.

10. Headrest with ange and height adjustment (apply to EMOTION.EXE).





emotion



emotion x



emotion q



emotion v

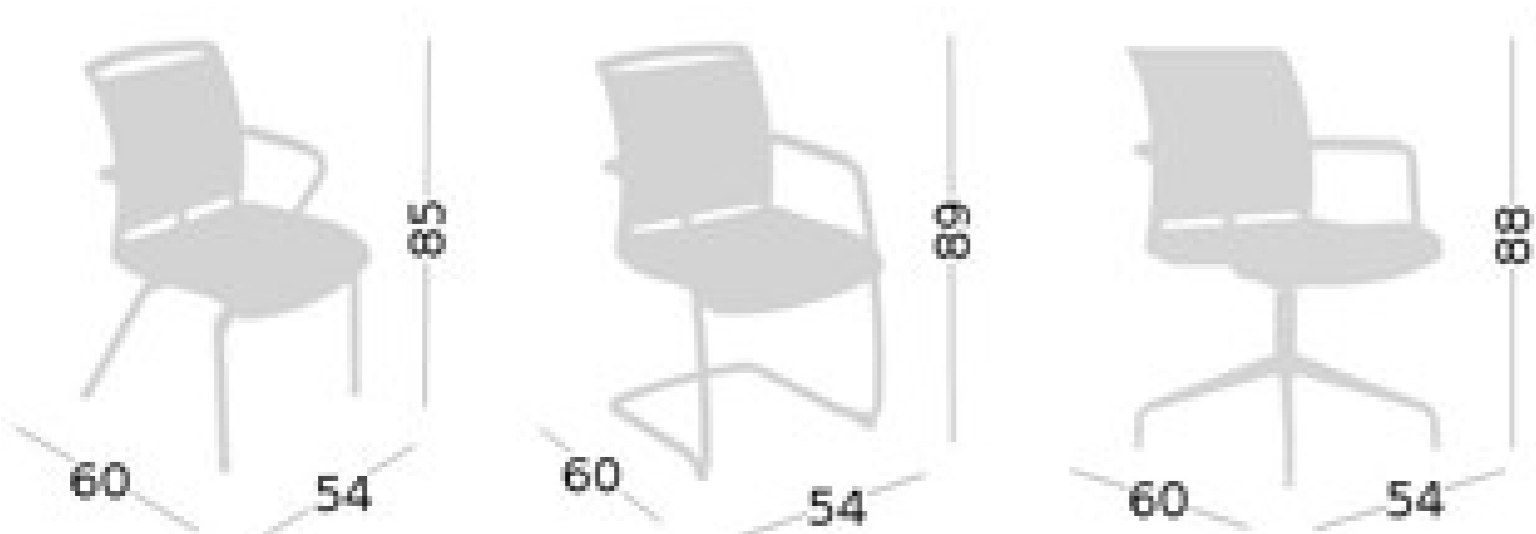



CLASS, CLASS.EXE

1. Ruch krzesła na kółkach.
2. Regulacja wysokości podnośnikiem pneumatycznym.
3. Obrót wokół własnej osi.
4. Mechanizm synchroniczny regulujący kąt nachylenia oparcia do 21° oraz kąt nachylenia siedziska do 9°, blokada w 5 pozycjach.
5. Przesuw poziomy siedziska (5 cm - 5 pozycji).
6. Regulacja wysokości oparcia (6 cm - 10 pozycji).

Modele zaopatrzone w regulowane podłokietniki:

7. Regulacja wysokości (8 cm - 8 pozycji)
8. Rotacja pozioma.
9. Przesuw przód-tył (6 cm).

10. Zagłówek o regulowanej wysokości i kącie nachylenia (dotyczy CLASS.EXE).

1. Movement on castors.
2. Gas height adjustment of the seat.
3. Rotation on axis.
4. Synchron mechanism seat/back lockable in 5 positions with tension adjustment and anti-shock system.
5. Sliding seat (5 cm. - 5 pos.)
6. Height adjustment of the back (6 cm. - 10 pos.)

Models with adjustable armrests:

7. Height adjustment (8 cm. - 8 pos.)
8. Horizontal sliding.
9. Forward-back adjustment (6 cm).

10. Headrest with angle and height adjustment (apply to CLASS.EXE).



class



class v



kvadro



KVADRO

1. Ruch krzesła na kółkach.
2. Regulacja wysokości podnośnikiem pneumatycznym.
3. Obrót wokół własnej osi.
4. Mechanizm synchroniczny regulujący kąt nachylenia oparcia.
5. Przesuw poziomy siedziska (5 cm).
6. Regulacja wysokości oparcia (8 cm).

Modele zaopatrzone w regulowane podłokietniki:

7. Regulacja wysokości (10 cm - 8 pozycji)
9. Rotacja pozioma 30° i regulowany rozstaw.

1. Movement on castors.
2. Gas height adjustment of the seat.
3. Rotation on axis.
4. Synchron mechanism seat/back lockable.
5. Sliding seat (5 cm).
6. Height adjustment of the back (8 cm).

Models with adjustable armrests:

7. Height adjustment (10 cm. - 8 pos.)
8. Horizontal sliding and 30° totation.



kvadro v

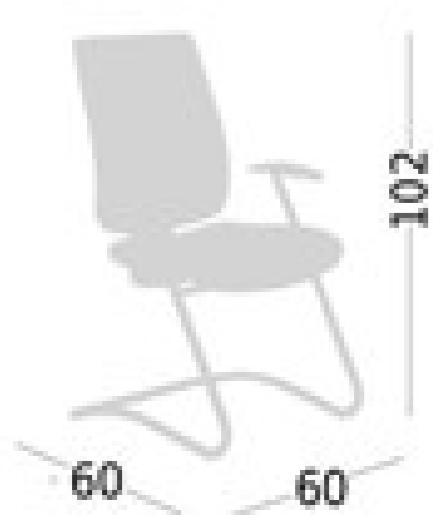

max



MAX

1. Ruch krzesła na kółkach.
2. Regulacja wysokości podnośnikiem pneumatycznym.
3. Obrót wokół własnej osi.
4. Mechanizm synchroniczny regulujący kąt nachylenia oparcia do 21° oraz kąt nachylenia siedziska do 9°, blokada w 5 pozycjach.
5. Przesuw poziomy siedziska (5 cm - 5 pozycji).
6. Regulacja wysokości oparcia (6 cm - 10 pozycji).

Modele zaopatrzone w regulowane podłokietniki:
7. Regulacja wysokości (10 cm - 8 pozycji)
8. Rotacja pozioma 30° i regulowany rozstaw.

1. Movement on castors.
2. Gas height adjustment of the seat.
3. Rotation on axis.
4. Synchron mechanism seat/back lockable in 5 positions with tension adjustment and anti-shock system.
5. Sliding seat (5 cm. - 5 pos.)
6. Height adjustment of the back (6 cm. - 10 pos.)

Models with adjustable armrests:
7. Height adjustment (10 cm. - 8 pos.)
8. Horizontal sliding and 30° rotation.



trans*



trans x



trans v



trans q

* -Trans (oparcie przezroczyste). Minimalna ilość zamówienia lub jej wielokrotność wynosi 10 sztuk.

Trans (transparent back). The minimum order quantity is 10 pcs, and the order quantity should be the multiple of 10.

* -Trans (oparcie plastikowe). Minimalna ilość zamówienia lub jej wielokrotność wynosi 16 sztuk.

Trans (plastic back). The minimum order quantity is 16 pcs, and the order quantity should be the multiple of 16.



evolution

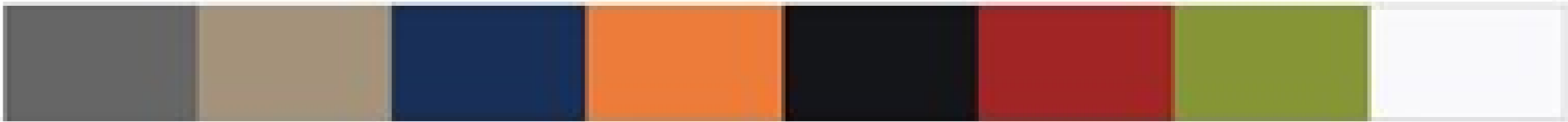

evolution



fly

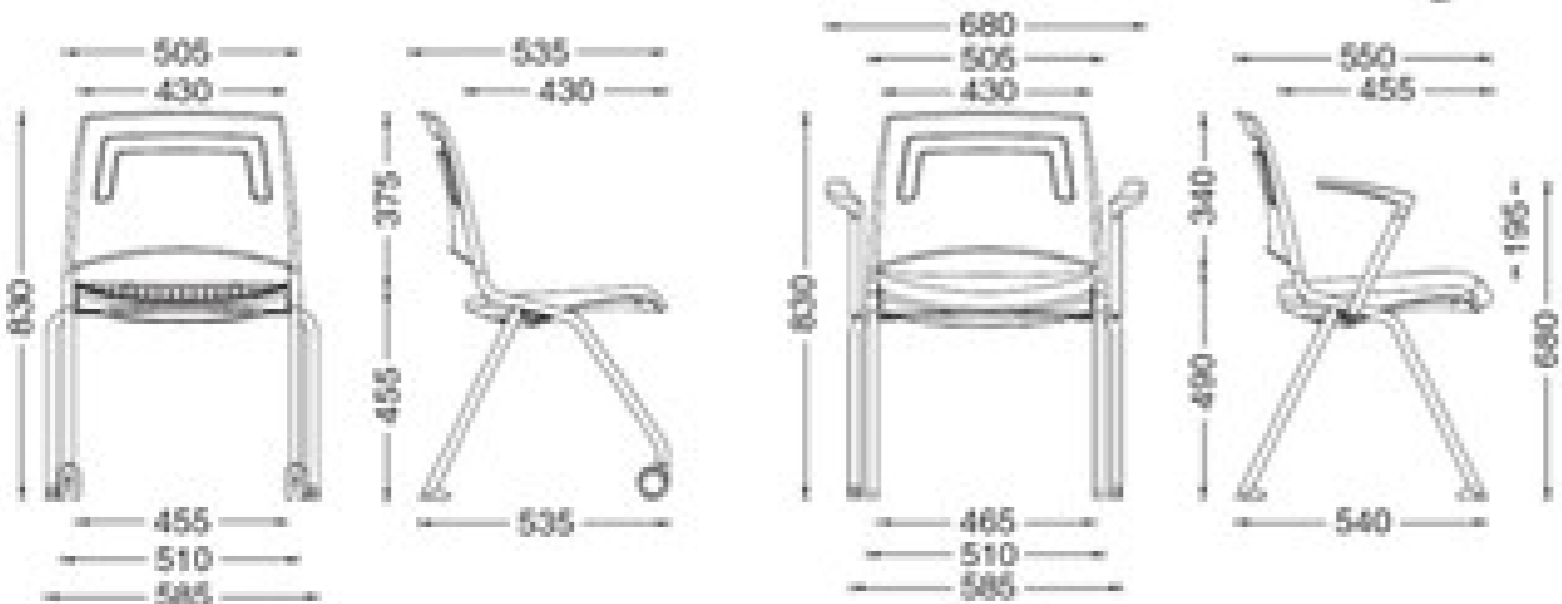

kadr



wing

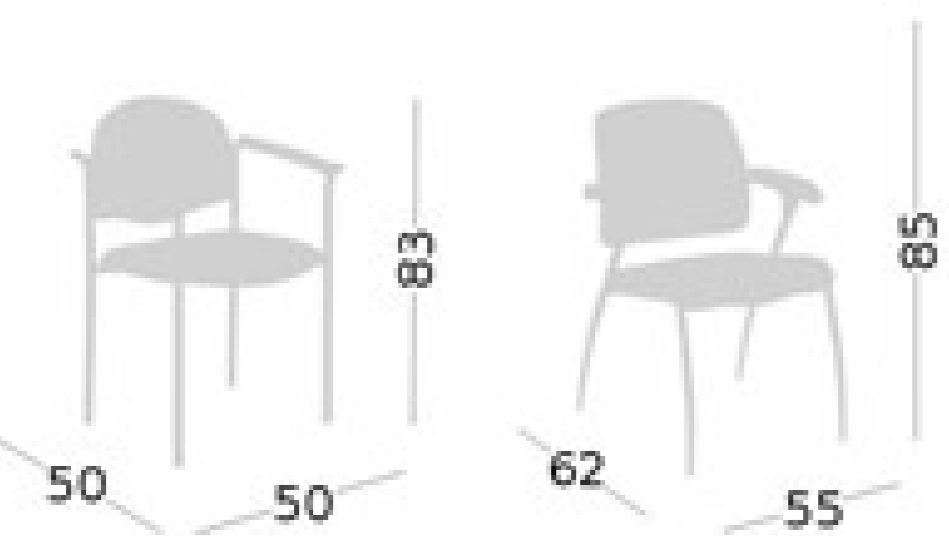

malika*



malika a



malika b



malika d



malika c



* -minimalna ilość zamówienia lub jej wielokrotność wynosi 15 sztuk - Malika A, C, D.

The minimum order quantity is 15 pcs, and the order quantity should be the multiple of 15 - Malika A, C, D.

* -minimalna ilość zamówienia lub jej wielokrotność wynosi 30 sztuk - Malika B.

The minimum order quantity is 30 pcs, and the order quantity should be the multiple of 30 - Malika B.

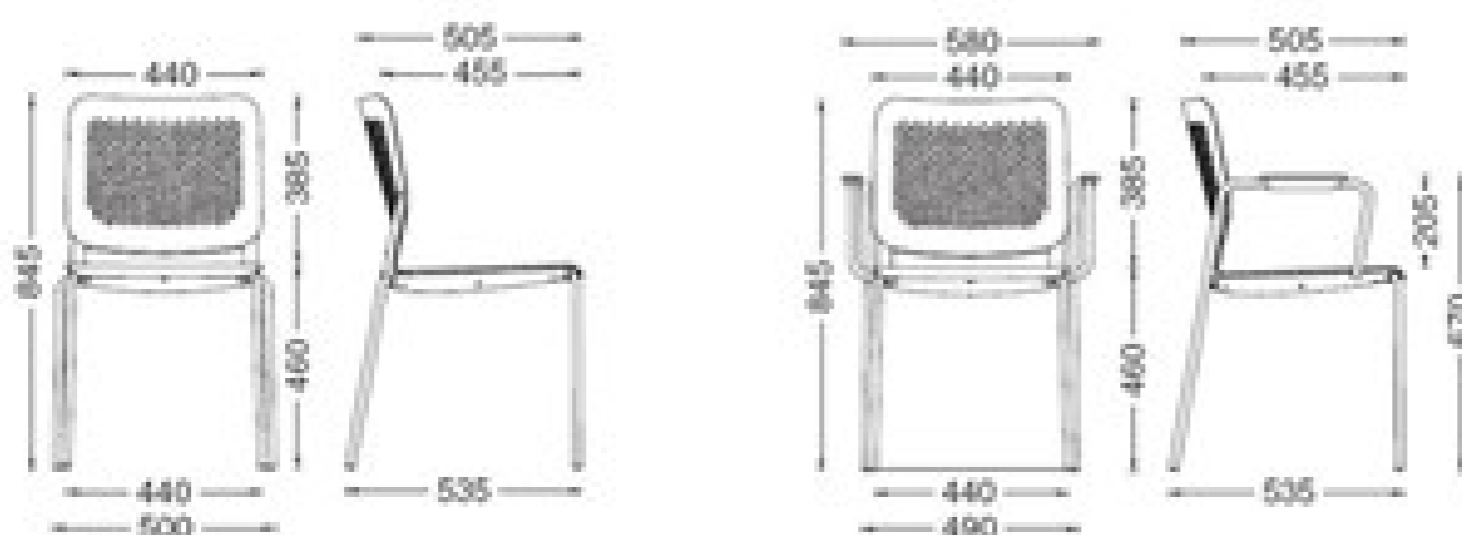

próbnik kolorów the samples

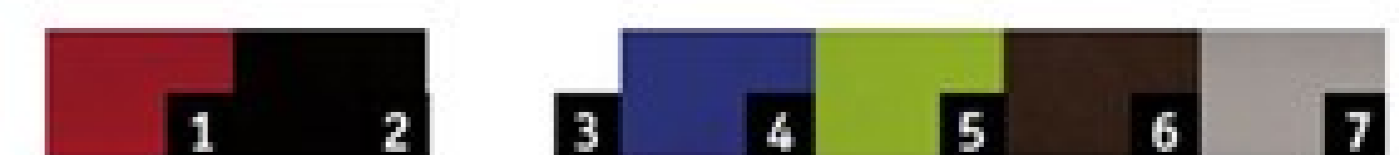

fresh

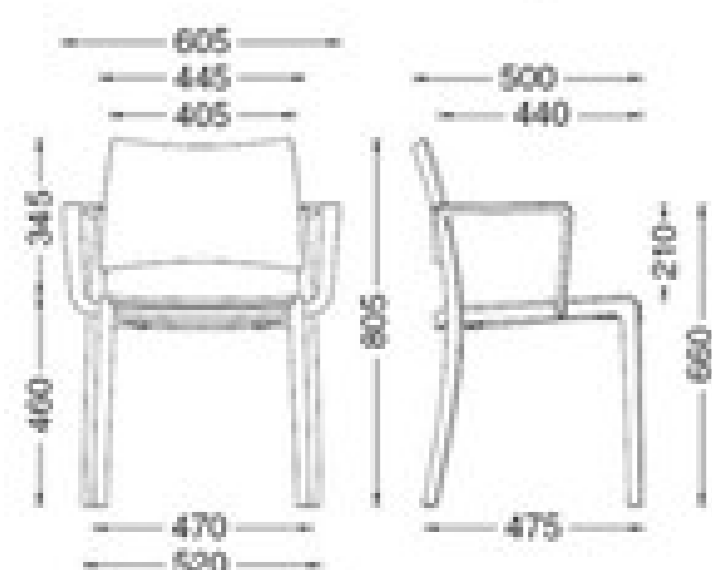

próbnik kolorów the samples



ecco



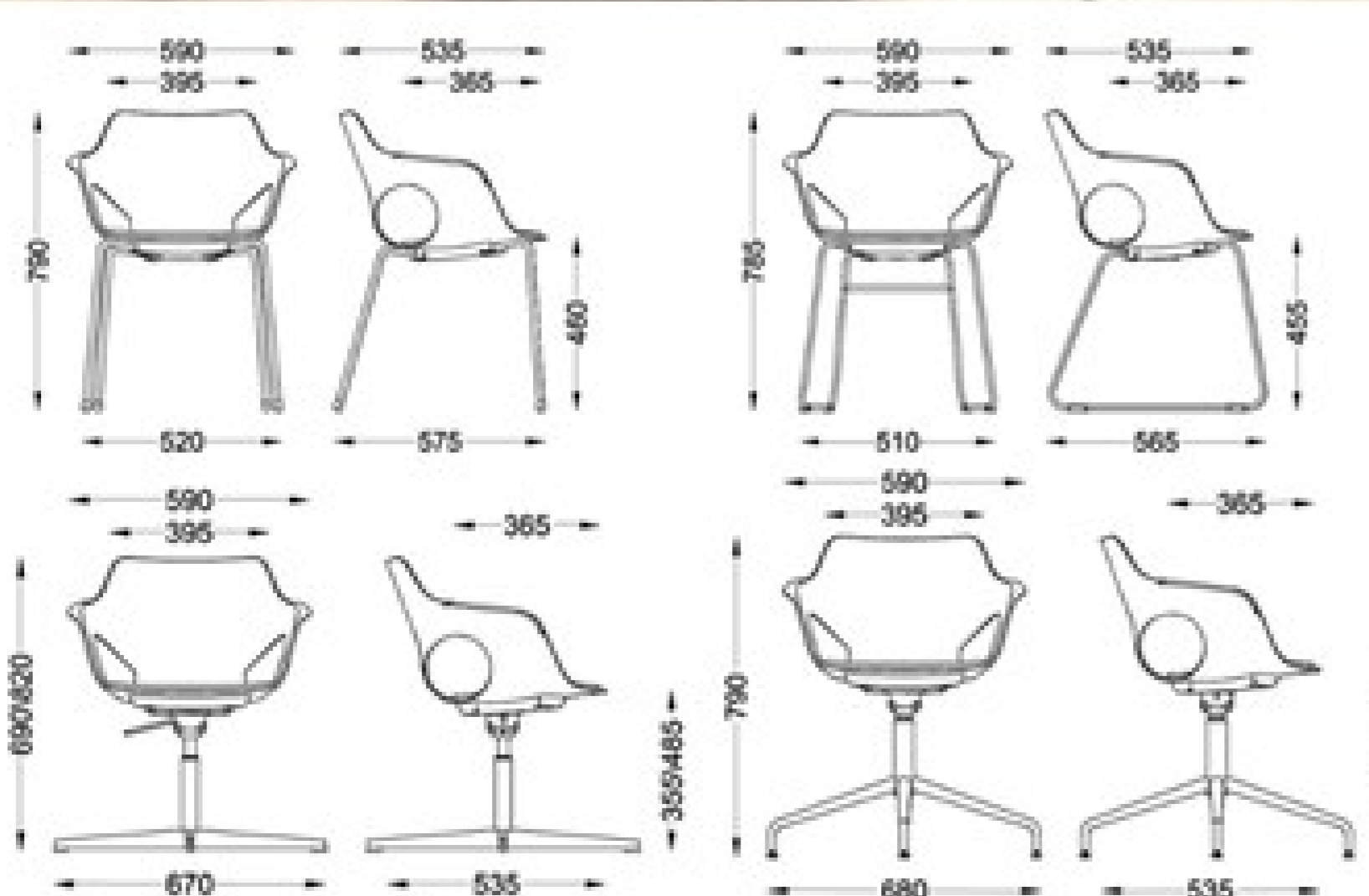

* -minimalna ilość zamówienia lub jej wielokrotność wynosi 5 sztuk.

The minimum order quantity is 5 pcs, and the order quantity should be the multiple of 5.

próbnik kolorów the samples

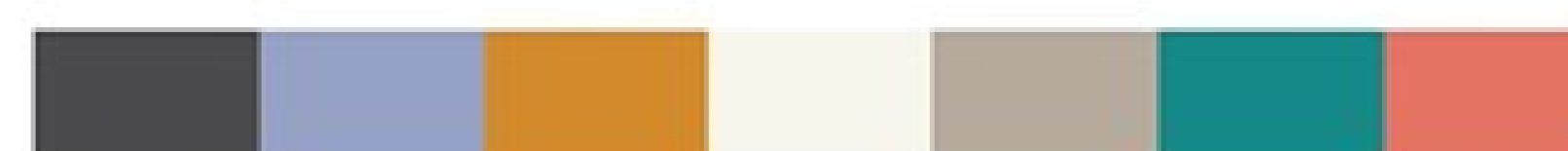

penta



próbnik kolorów the samples

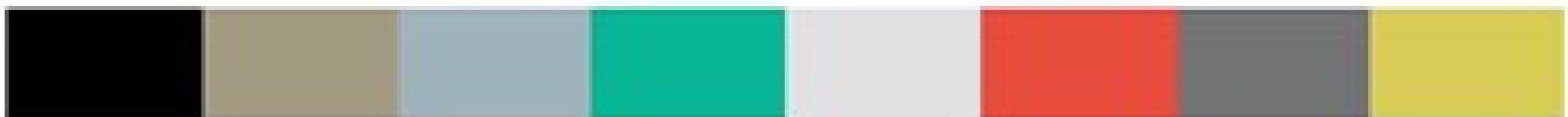



gloss a

gloss b



* -minimalna ilość zamówienia lub jej wielokrotność wynosi 5 sztuk.

The minimum order quantity is 5 pcs, and the order quantity should be the multiple of 5.

próbnik kolorów the samples

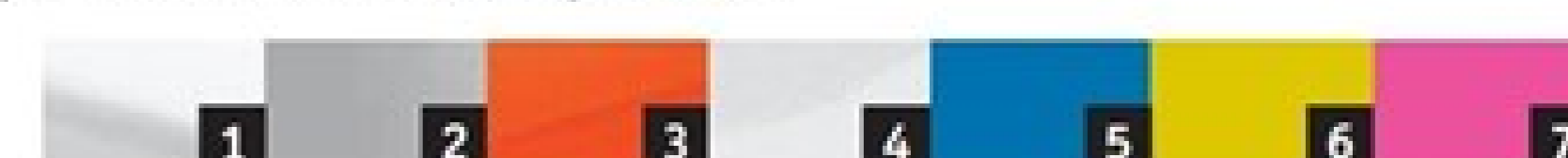

layer*



* -minimalna ilość zamówienia lub jej wielokrotność wynosi 10 sztuk.

The minimum order quantity is 10 pcs, and the order quantity should be the multiple of 10.

próbnik kolorów the samples

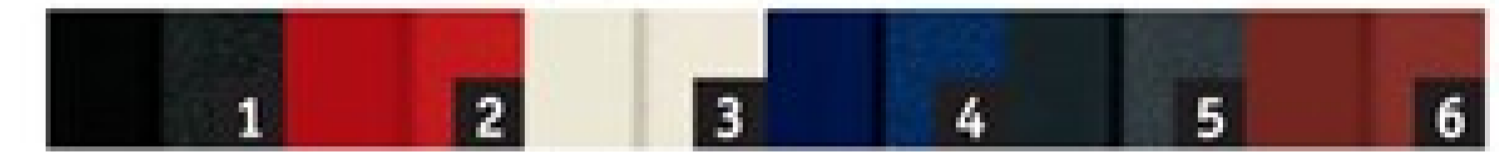

ari*



ari a



ari b

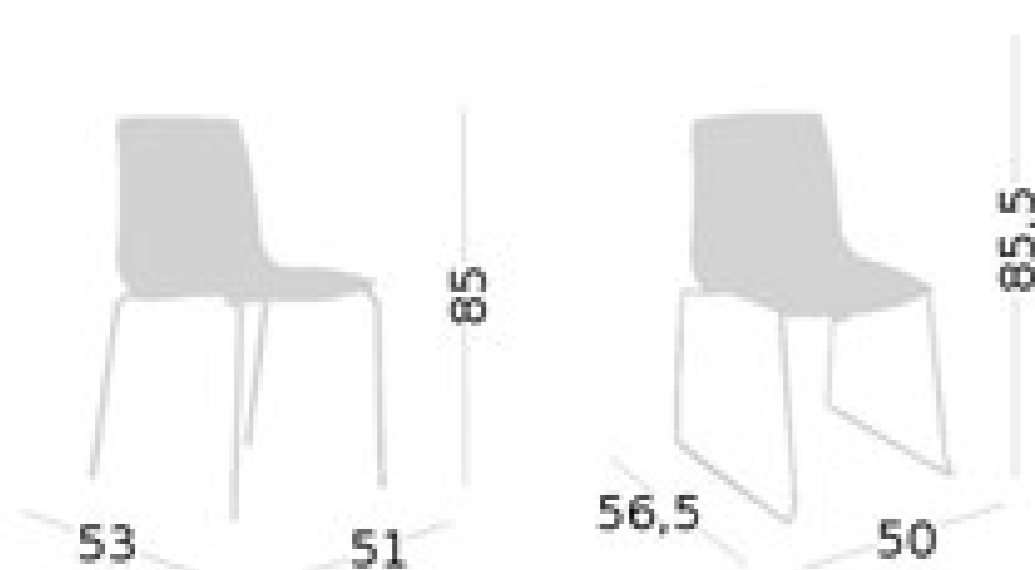

* -minimalna ilość zamówienia lub jej wielokrotność wynosi 5 sztuk.

The minimum order quantity is 5 pcs, and the order quantity should be the multiple of 5.

próbnik kolorów the samples

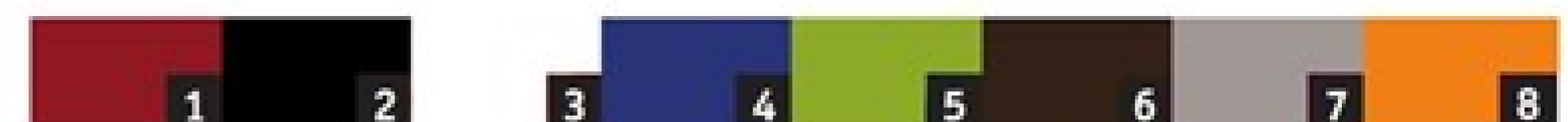

oval

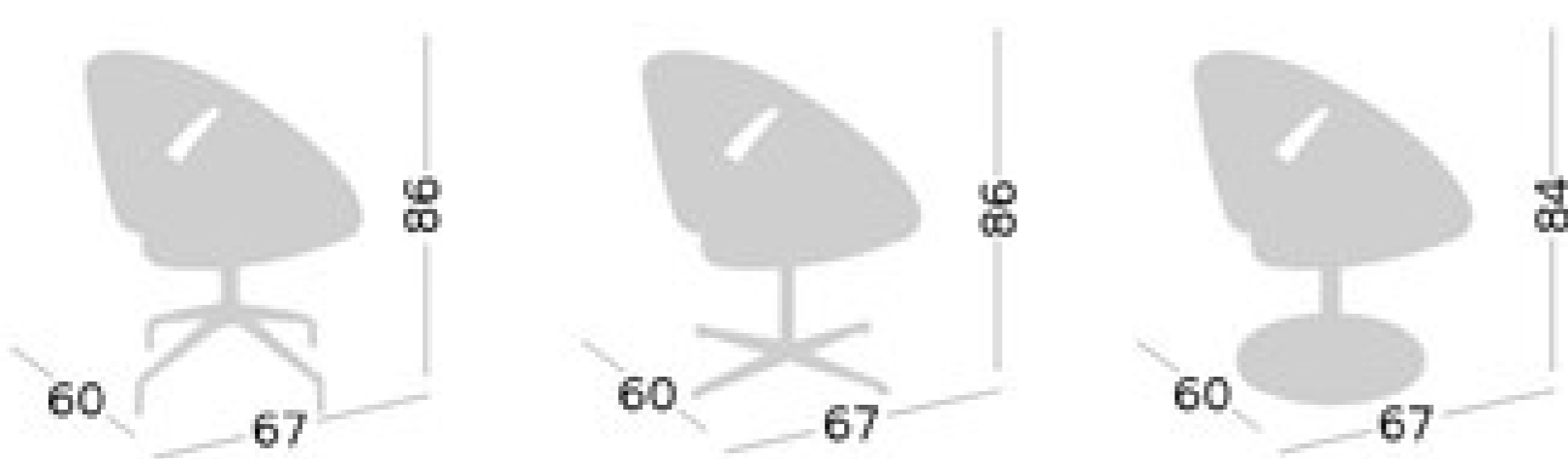

ancra



34

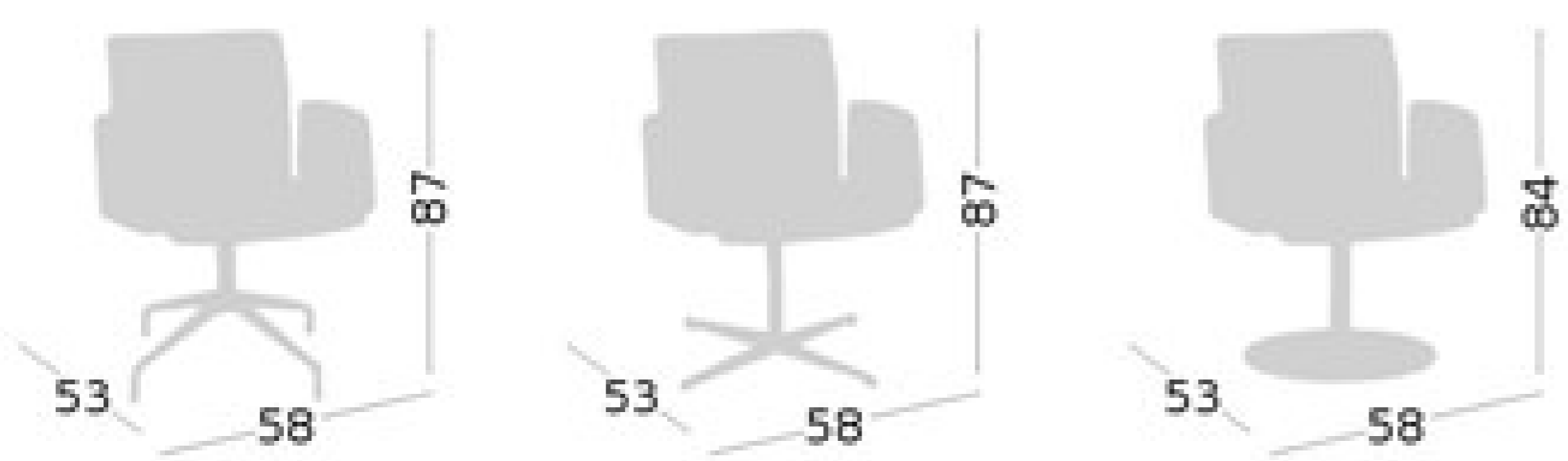

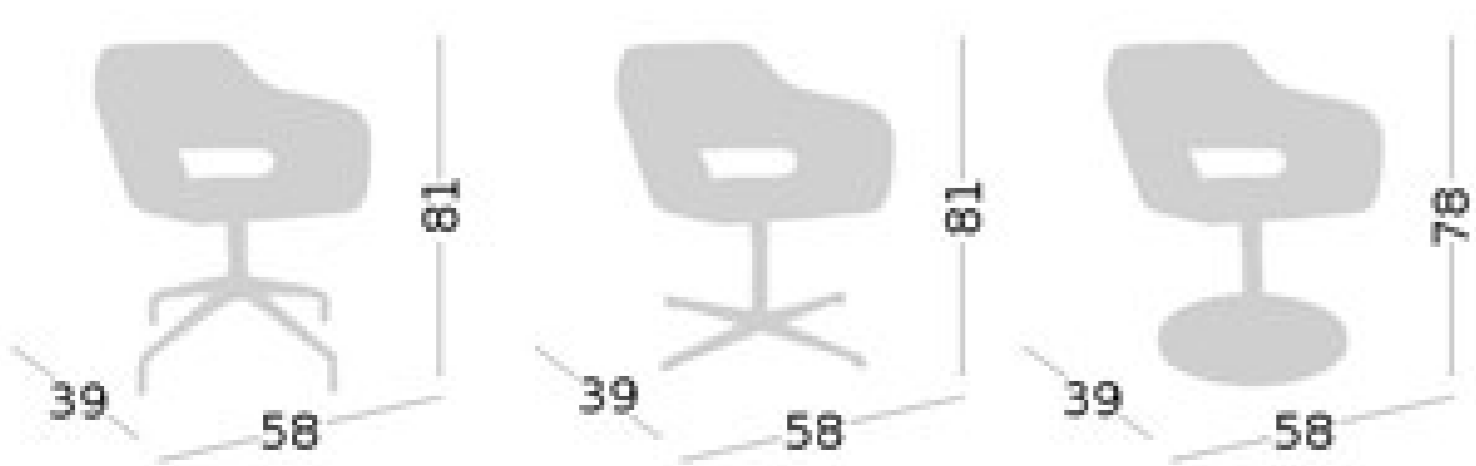

icon

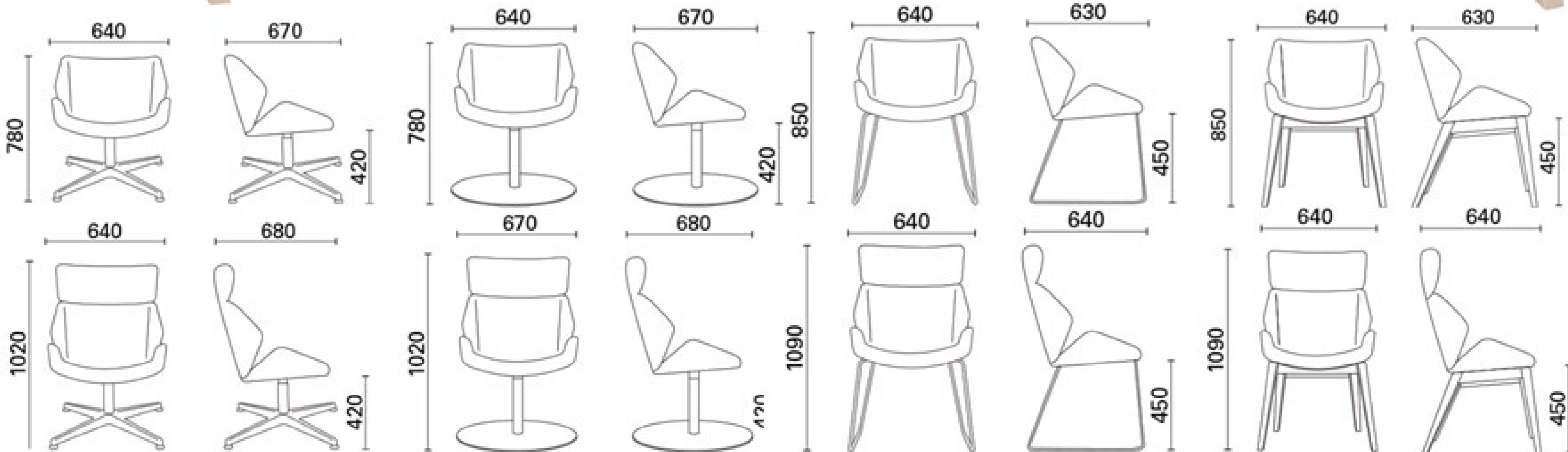

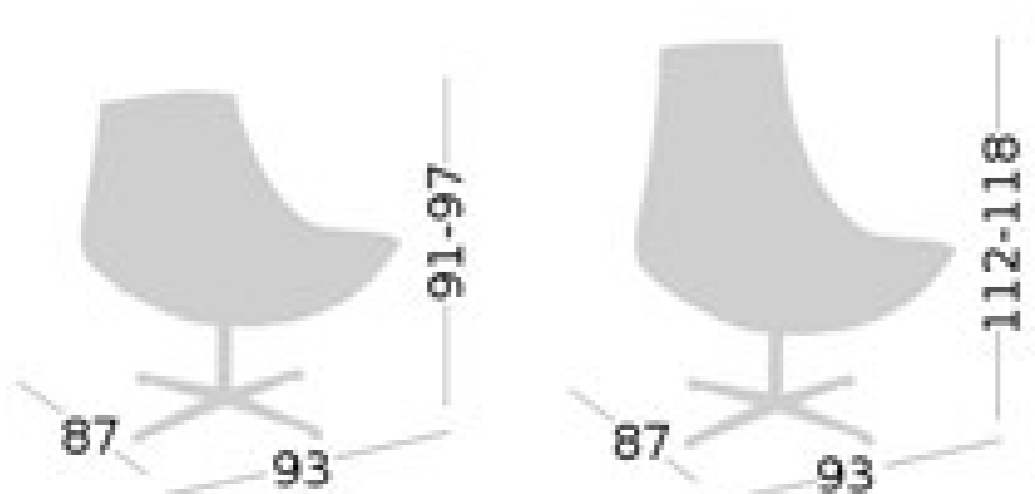

sofia

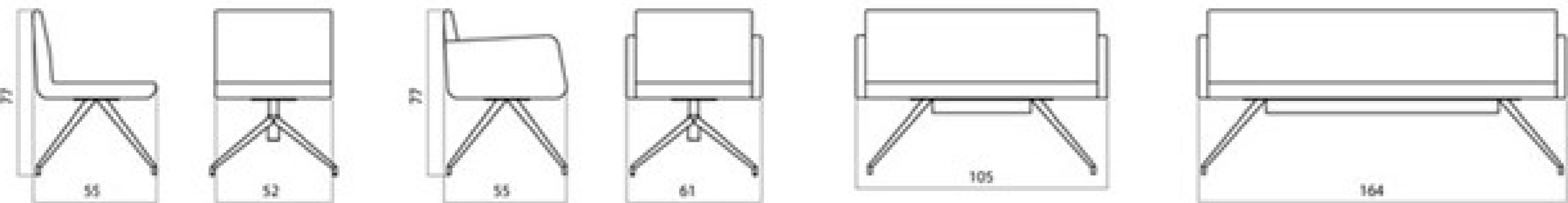

sofia



one



40

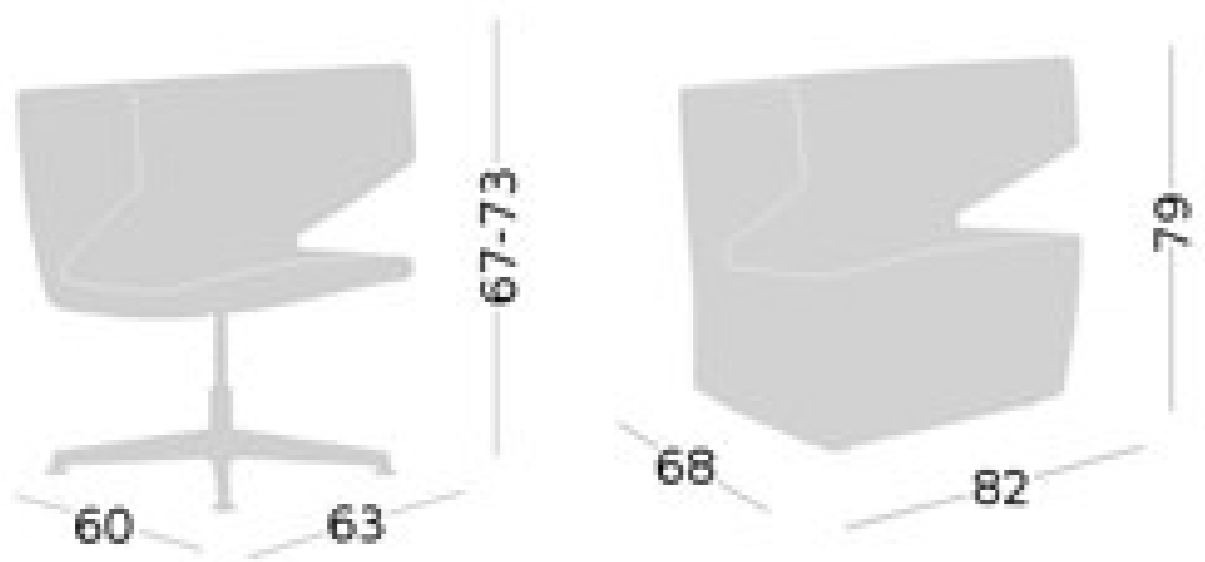

cube

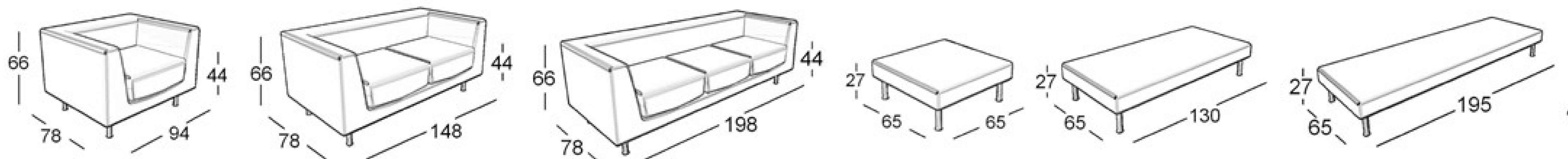

cube

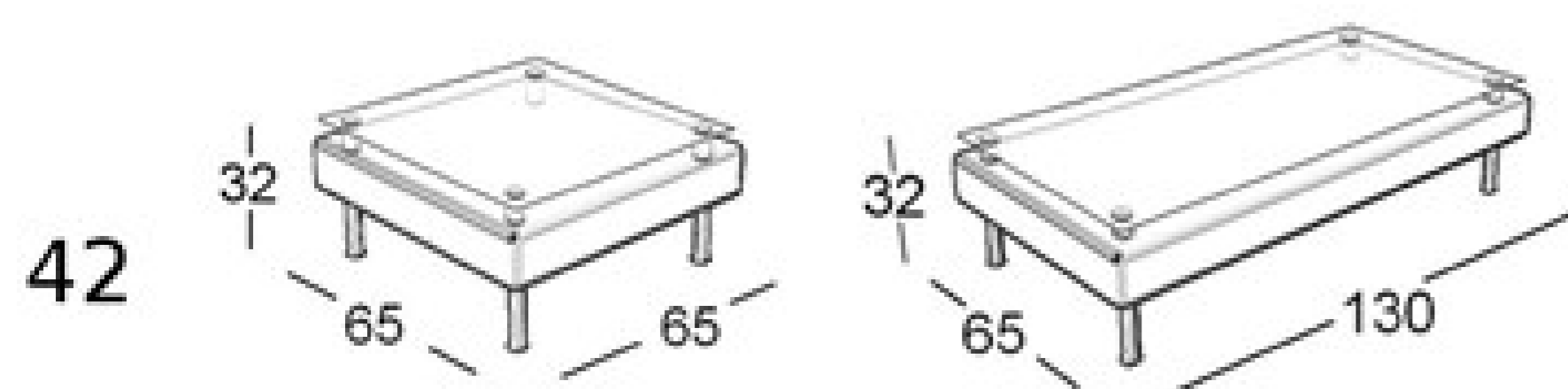



argo

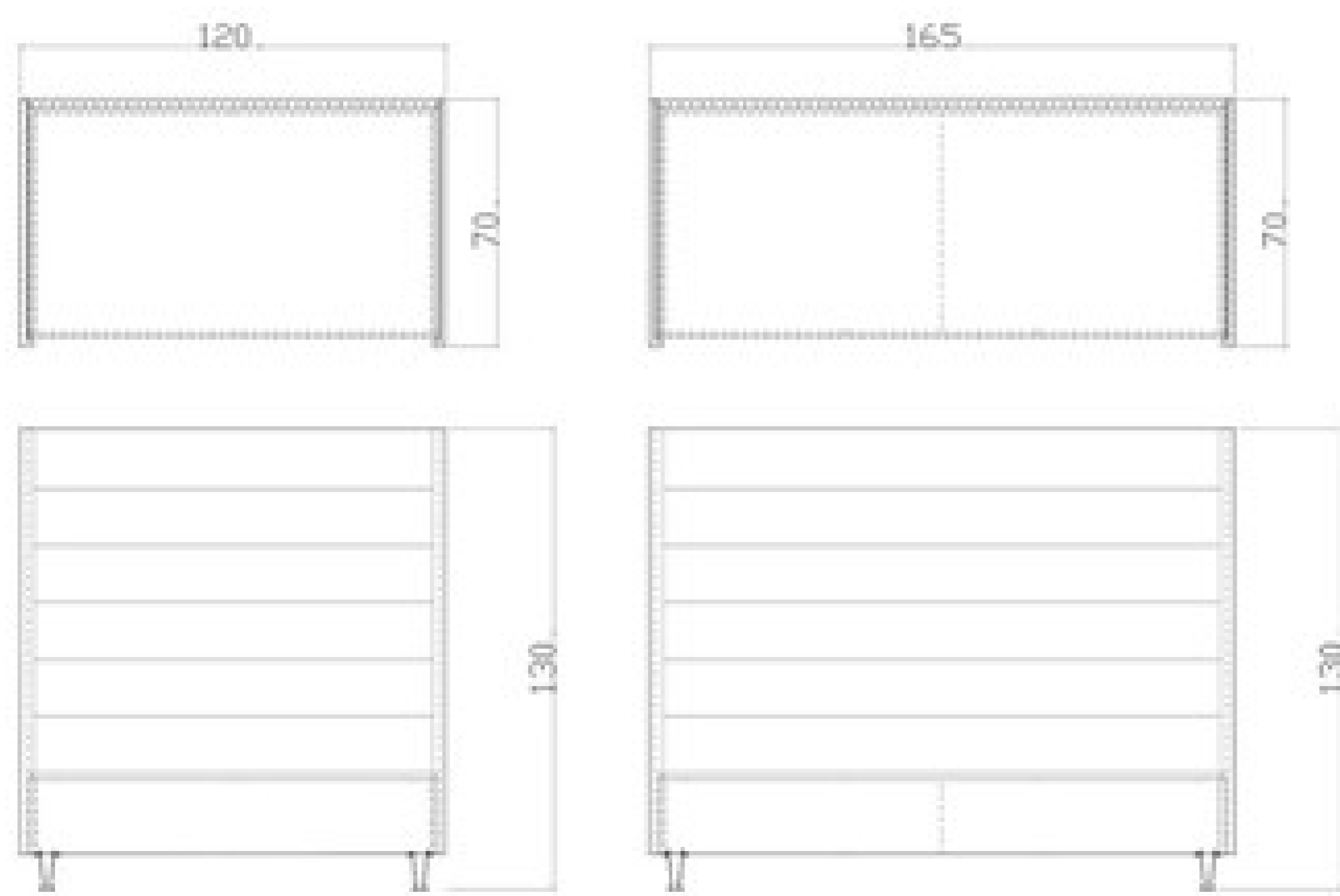



tilt

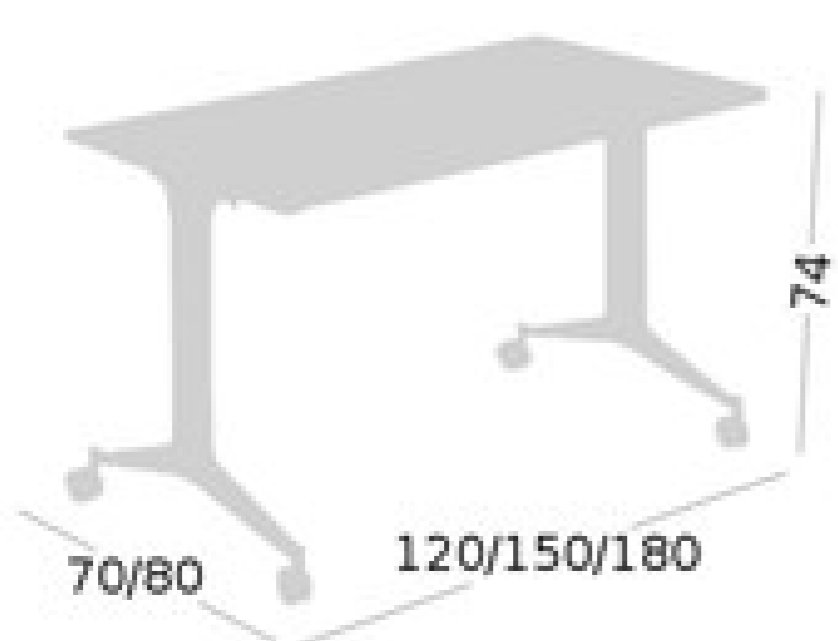

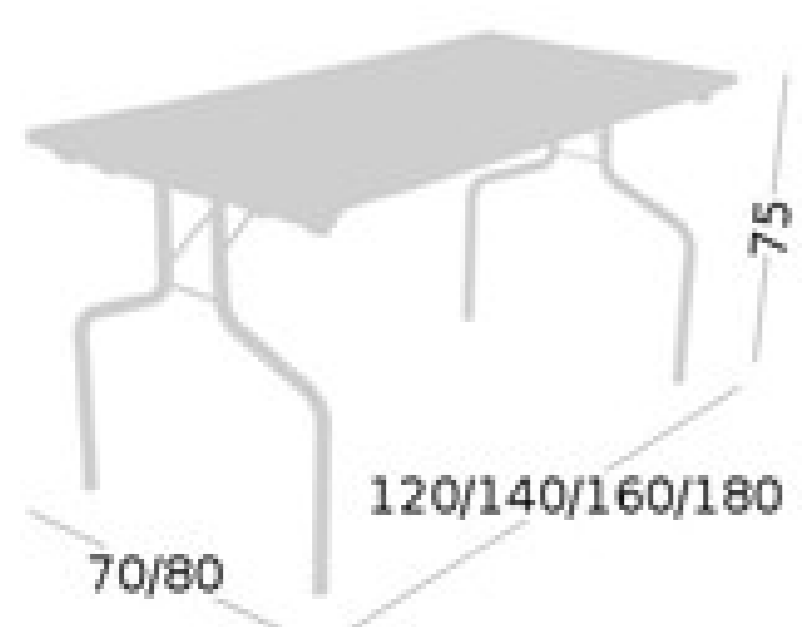

x-table

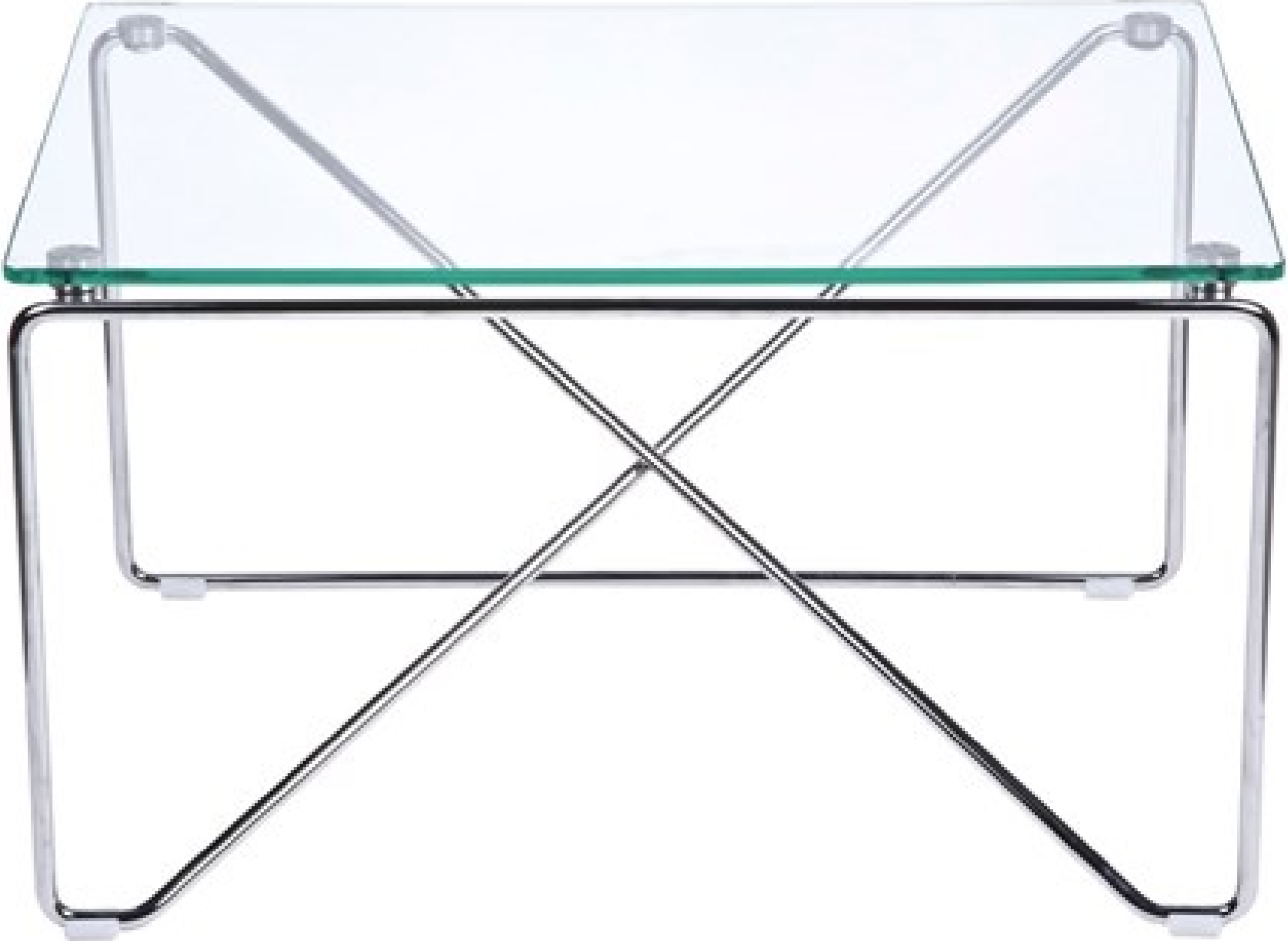
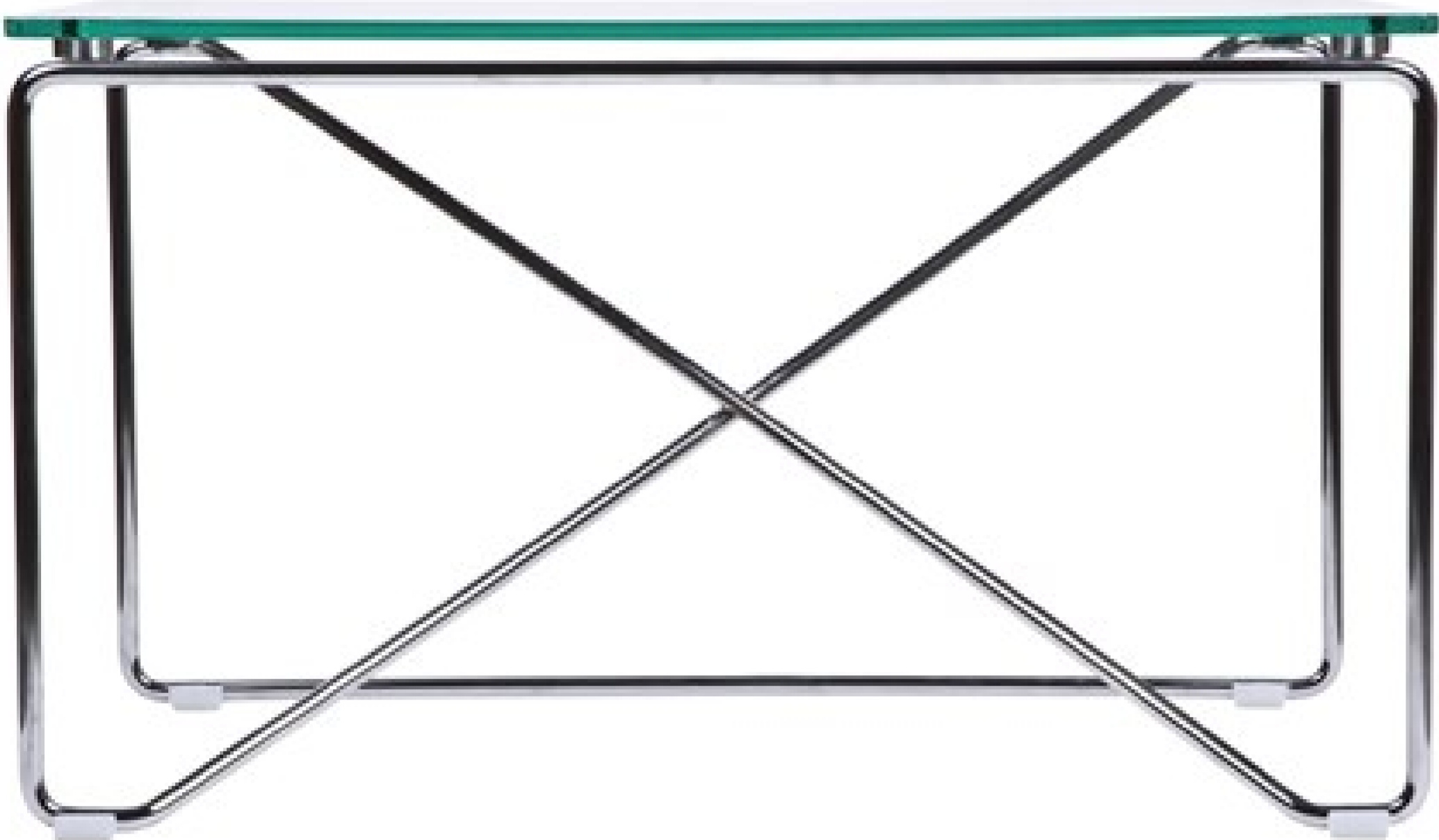

flexa



48

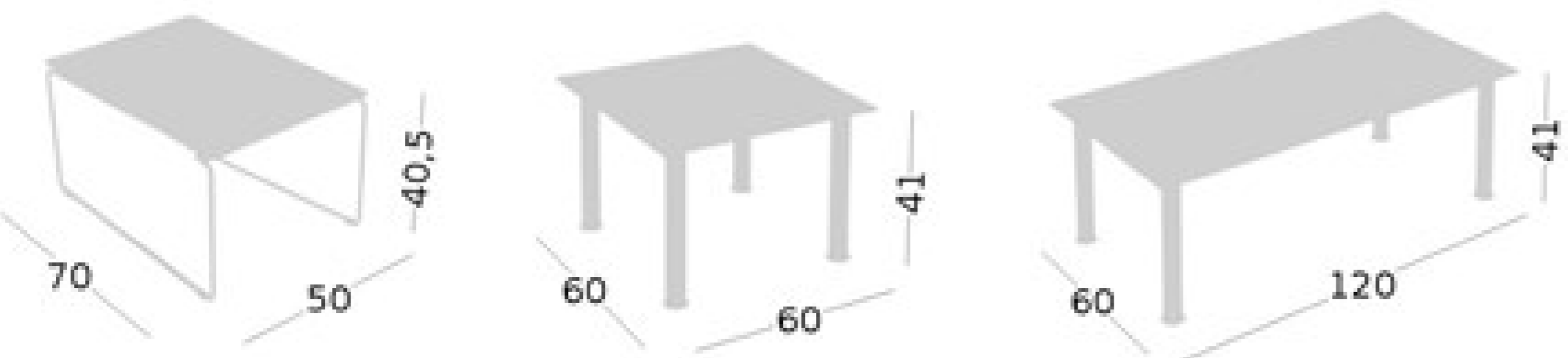



EURONOVA SP. Z O.O. SP. K.

UL. WROBELA 5
30-798 KRAKÓW

TEL. +48 12 429 15 39, 12 429 42 02
FAX +48 12 430 01 41

e-mail: euronova@euronova.pl
<http://www.euronova.pl>